



**Yes, you can.<sup>®</sup>**

**Invacare<sup>®</sup> Reliant 100/150/  
200/250<sup>™</sup>**

---

***User's Manual***



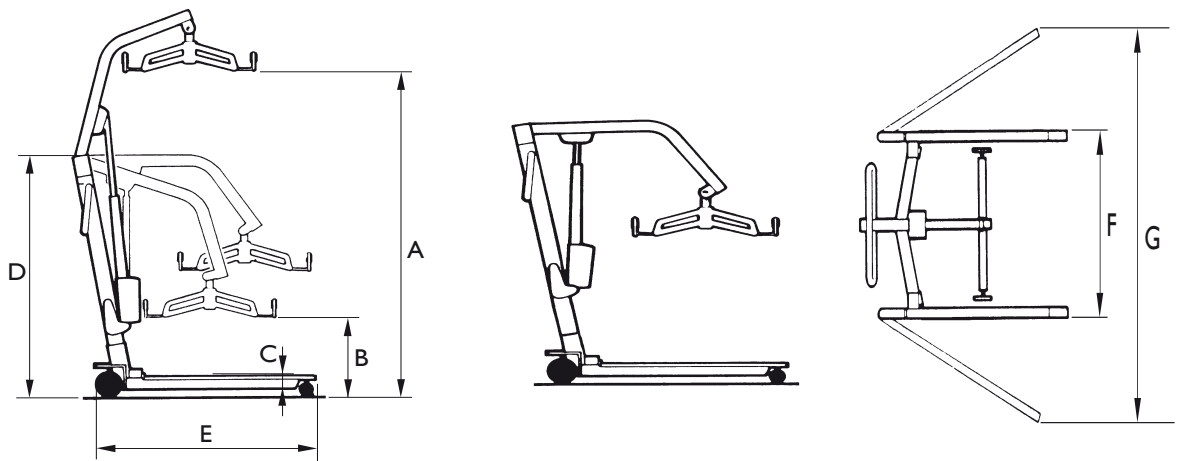

	<b>REL100</b>	<b>REL150</b>	<b>REL200</b>	<b>REL250</b>
<b>A</b>	163 cm	154 cm	161 cm	165 cm
<b>B</b>	45 cm	38 cm	41 cm	43 cm
<b>C</b>	11 cm	11 cm	11 cm	11 cm
<b>D</b>	113 cm	113 cm	120 cm	129 cm
<b>E</b>	100 cm	100 cm	118 cm	117 cm
<b>F</b>	62 cm	62 cm	67 cm	62 cm
<b>G</b>	91 cm	91 cm	104 cm	104 cm

Fig. 1

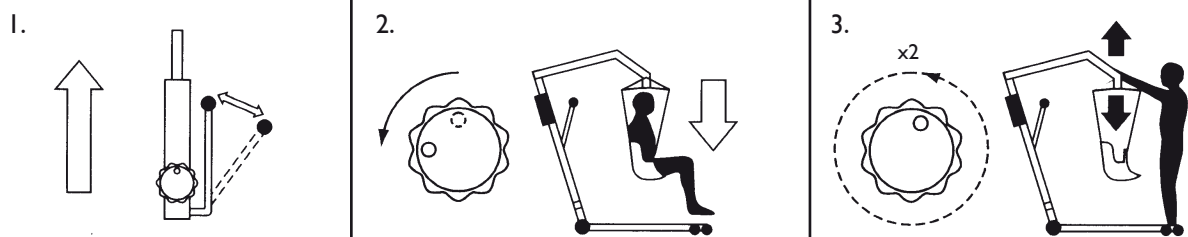

Fig. 2



Fig. 3

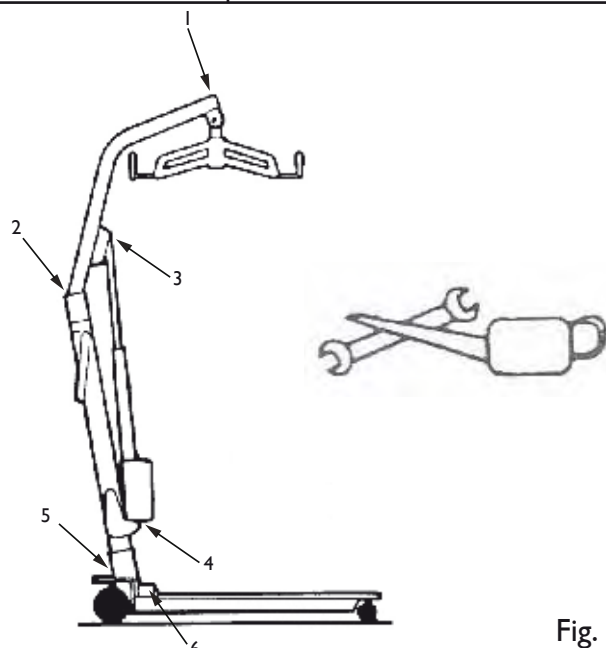

Fig. 4

# Quality Declaration

Congratulations with your new hoist Invacare® **Reliant™** from Invacare® EC-Høng A/S.

Your new hoist is **CE**-marked in accordance with directive 93/42/EEC concerning medical devices.

Invacare® **Reliant™** is developed and constructed with consideration for the user and others handling or assisting with lifting.

Invacare® **Reliant™** is supervised and quality controlled throughout the entire production process, and the finished hoist is inspected by our finished goods control.

Please read the entire user's manual before using the hoist.

Invacare® EC-Høng A/S is certified according to ISO 9001 and ISO 13485.

For and on behalf of Invacare® EC-Høng A/S:



---

Technical Manager  
**Carsten Borup**

## DE

## KONFORMITÄTSERKLÄRUNG

Herzlichen Glückwunsch zu Ihrem neuen Deckenlift Invacare® Reliant™ von Invacare® EC-Høng A/S.  
Ihr neuer Deckenlift ist gemäß der Richtlinie 93/42/EWG für Medizinprodukte CE-gekennzeichnet.  
Der Invacare® Reliant™ wurde unter Berücksichtigung der Bedürfnisse von Benutzer und Pflegepersonal entwickelt.  
Während des gesamten Herstellungsprozesses unterliegt der Invacare® Reliant™ einer ständigen Qualitätskontrolle und wird im Anschluss nochmals durch unsere Endkontrolle geprüft.  
Bitte lesen die gesamte Bedienungsanleitung, bevor Sie den Deckenlift in Gebrauch nehmen.  
Invacare® EC-Høng A/S ist zertifiziert nach ISO 9001 und ISO 13485.

## NL

## KWALITEITSGARANTIE

Gefeliciteerd met de aanschaf van uw nieuwe plafondlift Reliant™ van Invacare® EC-Høng A/S.  
Invacare® Reliant™ is CE - gecertificeerd en goedgekeurd conform richtlijn 93/42/EEC betreffende medische hulpmiddelen.  
Invacare® Reliant™ is ontwikkeld en geconstrueerd met inachtneming van de behoeften van de gebruiker en verzorgers.  
Gedurende het gehele productieproces is het Reliant™ bed gecontroleerd op kwaliteitsaspecten en het complete plafondlift is na productie zorgvuldig gecontroleerd.  
Wij verzoeken u vriendelijk de gehele gebruikershandleiding te lezen voordat u het plafondlift in gebruik neemt.  
Invacare® EC-Høng A/S is ISO 9001 en ISO 13485 gecertificeerd.

## IT

## DICHIARAZIONE DI QUALITÀ

Complimenti per aver scelto il sollevatore da soffitto Invacare® Reliant™ prodotto da Invacare® EC-Høng A/S.  
Il vostro nuovo il sollevatore da soffitto è marcato CE - ai sensi della Direttiva 93/42/EEC relativa ai dispositivi medici.  
Il il sollevatore da soffitto è stato progettato e costruito con un occhio di riguardo per gli utilizzatori e per i loro assistenti. Il sollevatore da soffitto è stato oggetto di accurate verifiche qualitative durante l'intero processo produttivo; una volta completato è stato controllato dal nostro servizio prodotti finiti.  
Prima di utilizzare il il sollevatore da soffitto vi invitiamo a leggere integralmente il manuale d'uso.  
Invacare® EC-Høng A/S è un'azienda certificata ai sensi della Normativa ISO 9001 e ISO 13485.

## ES

## DECLARACIÓN DE CALIDAD

Enhorabuena por su nueva elevador de techo Invacare® Reliant™ de Invacare® EC-Høng A/S.  
Su nueva elevador de techo cuenta con el marcaje CE - de acuerdo a la directiva 93/42/EOF que hace referencia a los aparatos médicos.  
Invacare® Reliant™ ha sido diseñada y fabricada teniendo en cuenta a los usuarios y las personas que los asisten.  
El proceso de producción del modelo Invacare® Reliant™ ha sido supervisado en su totalidad y su calidad inspeccionada, por nuestro control de producto acabado.  
Por favor lea el manual antes de utilizar la elevador de techo.  
Invacare EC-Høng A/S es una empresa certificada ISO 9001 e ISO 13485

## FR

## DÉCLARATION DE QUALITÉ

Félicitations! Vous avez choisi votre nouveau lève-personnes Invacare® Reliant™ de Invacare® EC-Høng A/S.  
Votre nouveau lève-personnes est marqué CE conformément à la directive 93/42/EEC concernant les dispositifs médicaux.  
Invacare® Reliant™ a été développé et construit en considérant systématiquement les besoins de l'utilisateur et des tierces personnes lors de la manipulation du lève-personnes ou de son utilisation. Invacare® Reliant™ a été supervisé et contrôlé tout au long du processus de fabrication et le lève-personnes achevé a été inspecté par le contrôle des produits finis. Le lève-personnes répond aux exigences de l'analyse de risques de la norme NF EN 14971. Nous vous remercions de lire le Manuel de l'Utilisateur dans son intégralité avant d'utiliser le lève-personnes.  
Invacare® EC-Høng A/S est certifiée ISO 9001 et ISO 13485.

## PT

## DECLARAÇÃO DE QUALIDADE

Parabéns pela sua nova elevador de transferência Invacare® Reliant™ da Invacare® EC-Høng A/S.  
A elevador de transferência tem a marca CE - em conformidade com a directiva 93/42/EEC referente a aparelhos médicos.  
A elevador de transferência foi concebida e desenhada, tendo em consideração o seu utilizador e o seu(s) assistente(s), que o ajudarão a manipular a elevador de transferência.  
Durante todo o processo de fabrico e produção, a elevador de transferência Invacare® Reliant™ foi supervisionada e a sua qualidade controlada, sendo o produto final inspeccionado e testado pelo nosso controlo de qualidade. Por Favor, leia atentamente este manual de utilizador antes de utilizar a sua elevador de transferência.  
A Invacare® EC-Høng A/S está certificada em conformidade com ISO 9001 e ISO 13485.

# Table of Contents

1.	<b>Assembly</b> .....	<b>6</b>
2.	<b>Operating instructions</b> .....	<b>8</b>
3.	<b>Battery charging</b> .....	<b>10</b>
4.	<b>Maintenance</b> .....	<b>10</b>
5.	<b>Troubleshooting</b> .....	<b>11</b>

## Congratulations

You have chosen *Invacare*®'s **Reliant 100/150/200/250** mobile hoist. **Reliant 100/150/200/250** mobile hoist is one of the most comprehensive in Europe.

It covers a wide spectrum of user needs from a basic, compact hydraulic model to a high-performance heavy-duty electrically operated model.

All our hoists are built to the most stringent high-quality standards where safety and reliability are the overriding criteria. They are easy to operate and user-friendly, both for the user and the attendant.

Please read this manual carefully before you start to use the hoist. It contains useful tips and information on safety, operation and maintenance.

In the event of any problems or queries, do not hesitate to contact the local *Invacare*® dealer who will be at your service for advice and assistance.

This manual is subject to change without prior notice in the interest of product improvement.

## I. Assembly

The hoist in the *Invacare*® range are designed for easy assembly. The only tools required are an adjustable spanner and a 5 mm Allan key.



**Caution!** Take the utmost care when lifting components during assembly. Always remember to adopt the correct lifting position.

### Assembled hoist weights are as follows:

- REL100 32 kg
- REL150 34 kg
- REL200 34 kg
- REL250 36 kg

### To assemble

1. Remove all parts from the carton.
2. Place the chassis assembly on the floor and apply the brakes, by pressing on the round pedal located on both rear castors.
3. For increased stability, widen the chassis legs by pressing down the right hand pedal at the back of the chassis.
4. Insert the mast and jib/actuator assemblies into the socket located in the chassis.
5. In the plastic bag supplied, you will find an 85 mm long screw, handle and a hexagon wrench.
6. From the rear of the hoist insert the 85 mm long screw through the location holes in chassis and mast ensuring the threaded end protrudes through to the inside of the hoist. Use the hexagon wrench to securely tighten the handle.
7. Connect the hand control cable to the control unit.
8. Using a spanner, mount the spreader bar to the moving part of the mast. Do not over-tighten the fixing nut.

Dismantling is the reversal of the assembly procedure.



It should never be necessary to dismantle the actuator from the jib, but in the unlikely event of having to do so always ensure the actuator is refitted to its original position, never in the hole blanked off by grommets. Not respecting this can lead to deformation of the actuator and eventually a hoist collapse.

The deformation of the actuator due to a change in the position on the jib or due to excess load are not covered by the warranty.

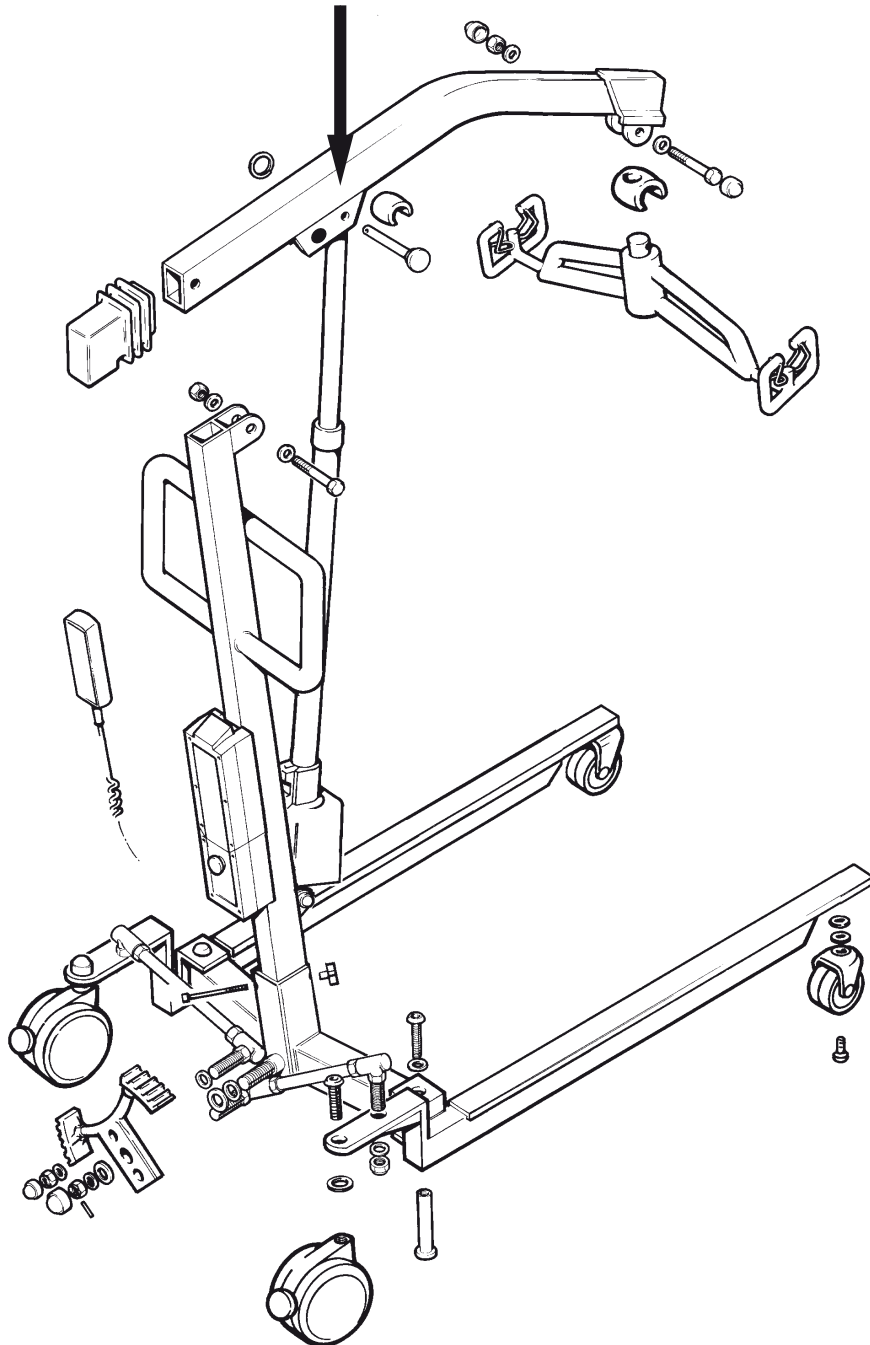

## 2. Operating instructions



**Important!** *Invacare*® do not recommend the operation of any mobile lifting equipment without prior professional training in moving and handling techniques.

### Never exceed the maximum recommended lifting capacity:

- REL100 130 kg
- REL150 130 kg
- REL200 175 kg
- REL250 175 kg

### Adjustment of chassis width

1. Stand behind the hoist and take a firm hold of both handles.
2. To open (widen) chassis legs - press the right foot pedal.
3. To close (narrow) chassis legs - press the left foot pedal.

### Brakes

1. Stand behind the hoist and take a firm hold of both handles.
2. To apply the brakes - press down the knob-shaped foot pedal in both rear castors.  
A red indicator button will show that brakes are applied.
3. To release the brakes - press the locking knob again.

### Moving the hoist

1. Stand behind the hoist and take a firm hold of both handles.
2. Narrow chassis legs.
3. Release brakes in both rear castors.
4. Push or pull the hoist and steer it as required. As the hoist is fitted with castors at both ends, it needs careful guiding and steering, especially when a user is suspended in the sling. However, with some practice the operator will be able to take full advantage of the increased manoeuvrability provided by this design, in particular when moving in tight areas as well as moving sideways.



It is recommended not to move the user with the jib at maximum height. Please note that it is more difficult to manoeuvre the hoist on carpeted or uneven/textured surfaces as opposed to wooden or flat surfaces; this is due to the starting forces required to initiate the movement that may create additional friction exerted on the castors.  
Take great care when moving the hoist on carpeted, wet, slippery, rough or uneven surfaces.  
Never use on slopes.

**Note:** To negotiate raised obstacles during movement of the unladen hoist, it is recommended to pull the hoist rearwards. Ensure that brakes are not engaged before lifting or lowering.

### Attaching slings

1. Select the sling best suited for the user in question. Do not attempt to lift any user without prior professional training. If in doubt ask your *Invacare*® dealer for advise.
2. Fit the sling to the user as instructed in the *Invacare*® sling user's guide.  
Take great care to ensure that the sling is fitted correctly, so that the user is comfortable and safe.
3. Manoeuvre the hoist, so that the spreader bar can be lowered to the sling loops as close as possible.
4. Widen the chassis legs for increased stability.
5. Lower the spreader bar and attach the 4 loops of the sling, sliding the loops under the safety clips in the hooks.
6. If the user is in a sitting position, lower the spreader bar to users chest, then move the hoist nearer to the user. Ensure that brakes are not engaged prior to lifting or lowering.



**Caution!** Do not lift or lower a patient with the brakes applied. Always let the hoist find the correct centre of gravity. Never attempt to lift a user outside the base area of the hoist. When lifting a user from the floor, the user must always be located between the two hoist legs, and never outside the area. To avoid injury, utmost care must be taken when raising and lowering a user. Never exceed the recommended maximum hoist weight, and never use the hoist in wet areas.



### Raising & lowering - *Reliant 100 and 200 Hydraulic Model*

(refer to Fig. 2)

1. Check that the handwheel at the base of the pump lever is turned fully clockwise.
2. Operate the pump lever in firm strokes until the spreader bar is sufficiently raised (refer to fig. 2-1).
- 3a. To lower with a user: Turn the handwheel at the base of the pump lever anticlockwise through a quarter turn only, in order to ensure a gentle descent and correct positioning of the user. Turn the knob clockwise to reset the control (refer to fig. 2-2).
- 3b. To lower without a user: Turn the handwheel at the base of the pump lever anticlockwise through two full turns (refer to fig. 2-3).

### Raising & lowering - *Reliant 150 & 250 electric models*

1. To raise the mast, press the **Up** arrow on the hand control.
2. To lower the mast, press the **Down** arrow on the hand control.

### Emergency lowering devices

The *Reliant 150 and 250* hoists feature the latest Emergency Lowering Devices in line with the 1997 CEN Standard for Patient Transfer Systems.

### Emergency powered lowering

(refer to Fig. 3)

Should the hand control on the *Reliant 150 or 250* fail, the mast can be lowered by pushing a pointed object, such as a pen or paper clip, into the “Emergency Lower” circular membranous switch located on the face of the charger unit, just below the red “Emergency Stop” button. The mast will descend for as long as the “Emergency Lower” switch is depressed.

Should it be necessary to use this switch, please consult your *Invacare*® dealer before using the hoist again.

### Emergency mechanical lowering

In case of either total power failure or the battery becoming flat whilst the hoist is in use, the *Reliant 150 and 250* models are fitted with a fail safe mechanical lowering device. To lower the mast in this instance, pull the red “Emergency Toggle” located on the top surface of the actuator. The mast will continue to descend as long as the toggle is pulled out.

Should it be necessary to use this system, please consult your *Invacare*® dealer before using the hoist again.

To activate the safety system, insert a screw driver into the hole of the red plastic mechanism and unscrew for five turns until an adjustment screw is visible. This procedure must always take place before the equipment is installed. To adjust the emergency descent speed in relation to the user's weight, screw in or out the adjustment screw, unscrew to increase speed, screw in to decrease speed. This adjustment must be made upon delivery at the place of use.



**Note!** The Emergency Mechanical Lowering System will only operate when there is a user in the hoist.

### 3. Battery charging

#### General

The **Reliant 150 and 250** models are supplied with an integral battery charger for optimum convenience. The batteries must be charged at regular intervals to ensure maximum hoist performance and long battery life. The battery system is fitted with an audible warning system to alert the user when the charge is becoming low. It is recommended that hoist is put on charge as soon as is feasible after this audible warning is heard.

#### Charging

Charge regularly overnight if the hoist has been in use during the day and immediately when the audible warning sounds during operation.

To charge the hoist, insert the charging lead into the socket at the base of the battery box. Connect the charger input plug into the mains and switch on the mains supply. A charging indicator on the control unit will light up. A full charging cycle lasts approximately 12 hours, but the charger will switch off automatically as soon as the battery is fully charged. Charging must be carried out in a well ventilated room.



While charging takes place the hoist cannot be used.  
Do not attempt to use the hoist if the battery housing is damaged.  
Replace the battery housing before further use.

### 4. Maintenance

#### a) General

The new *Invacare*® range of hoist's are designed for minimum maintenance, however a 6 regular monthly check and quick lubrication should ensure continued safety and reliability. Ensure batteries are regularly charged, preferably **EVERY NIGHT**. This will prolong their life and maintain peak performance. Keep hoist and slings clean and in perfect working order - any defect should be noted and reported to your dealer service agent as soon as possible.

#### b) Lubrication

(refer to fig. 4)

Lubricate all pivot points. Ensure all surplus of lubricant is removed from surface.

#### c) Chassis assembly

There is no maintenance of either the castors or brakes, other than cleaning, lubrication and checking axle and swivel bolts for tightness.

Remove all debris, fluff etc. from the wheel and swivel bearings.

Lubricate as shown on lubrication chart.

If the tyres, bearings or general condition require any further attention, it is recommended new parts are fitted - refer to the spare parts list.

#### d) Chassis adjustment mechanism

The chassis adjustment should not require any attention other than to check the squareness of the legs when set to narrow and to adjust the Ackerman linkage rods if necessary.

Check the free movement of the linkage rods and tighten or lubricate if necessary.

Check the response of the leg adjustment foot pedal when you press it with the foot. There should be some resistance to prevent the legs from opening or closing accidentally, but there should be sufficient free movement of the mechanism to operate satisfactorily in either direction when the pedals are fully pressed down.

**Any irregularity can be corrected as follows:**

1. From the pedal swivel bracket, remove the nut cap.
2. Remove the locking pin from the castellated nut.
3. To correct sluggishness in the foot pedals, tighten the nut.
4. To correct excessive stiffness in the foot pedal response, slacken the nut slightly.
5. Refit locking pin to castellated nut.
6. Replace nut cap.

**e) Wear or damage**

It is imperative to inspect at regular intervals all stressed parts, such as slings, spreader bar and all pivot points for any signs of fraying, cracking, deformation or deterioration. Any defective parts must be replaced immediately and the hoist must not be used until it has been repaired.

**f) Cleaning**

Slings should be washed regularly in accordance with the washing instruction label. The hoist structure can be cleaned with a non-abrasive cleansing cream. It is also recommended to remove the mast assembly from the chassis and to clean and coat the mating surfaces of mast and mounting socket with vaseline before re-assembly.

## 5. Troubleshooting

Symptoms	Faults	Remedy
Hoist feels loose.	Foot pressure loose.	Refer to section d) of <b>Maintenance instructions.</b>
Castors/brakes noisy or stiff.	Fluff or debris in bearings.	Refer to section e) of <b>Maintenance instructions.</b>
Noisy or dry sound pivots.	Needs lubrication.	Refer to section b) of <b>Maintenance instructions.</b>
Oil leaking from hydraulics.	Hydraulic pump in need of service.	Contact your supplier.
Hydraulic pump fails to lift when pumped.	a) Handwheel not fully closed. b) Hydraulic pump in need of service.	a) Close handwheel. b) Contact your supplier.
Electric actuator fails to lift when switch depressed.	a) Hand control or actuator connector loose. b) Batteries low. c) Red isolating knob pushed in.	a) Push connectors fully in. b) Charge batteries. c) Rotate clockwise to release.
Electric actuator fails to lower when the switch is depressed.	a) Hand control plug or connector is loose. b) Battery low. c) Red isolating knob pushed in. d) Hand control failure. e) Electric fault.	a) Push connectors fully in. b) Charge battery. c) Rotate clockwise to release. d) Press "Emergency Lower Switch". e) Pull "Emergency Toggle".



Yes, you can.®

## Customer Sales and Service

### Denmark

#### INVACARE A/S

Sdr. Ringvej 39  
DK-2605 Brøndby  
Phone: +45 36 90 00 00  
Fax: +45 36 90 00 01  
[www.invacare.dk](http://www.invacare.dk)  
[denmark@invacare.com](mailto:denmark@invacare.com)

### Sweden & Finland

#### INVACARE AB

Fagerstagatan 9 / Box 66  
S-163 91 Spånga  
Phone: +46 8 761 70 90  
Fax: +46 8 761 81 08  
[www.invacare.se](http://www.invacare.se)  
[sweden@invacare.com](mailto:sweden@invacare.com)

### Norway & Iceland

#### INVACARE AS

Grensesvingen 9  
Postbox 6230 Etterstad  
N-0603 Oslo  
Phone: +47 22 57 95 00  
Fax: +47 22 57 95 01  
[www.invacare.no](http://www.invacare.no)  
[norway@invacare.com](mailto:norway@invacare.com)

### Spain

#### INVACARE S.A.

C/Areny S/N  
Poligon Industrial de Celrà  
E-17460 Celrà (Girona)  
Phone: +34 972 49 32 00  
Fax: +34 972 49 32 20  
[www.invacare.es](http://www.invacare.es)  
[contactsp@invacare.com](mailto:contactsp@invacare.com)

### Switzerland

#### MOBITEC REHAB AG

Benkenstrasse 260  
CH-4108 Witterswil  
Phone: +41 61 487 70 80  
Fax: +41 61 487 70 81  
[switzerland@invacare.com](mailto:switzerland@invacare.com)

### Invacare® EC-Høng A/S

Ident. no.: 1496150

Version: 02

Date: 08.2008

### Belgium & Luxemburg

#### INVACARE N.V.

Autobaan 22  
B-8210 Loppem, Brügge  
Phone: +32 50 83 10 10  
Fax: +32 50 83 10 11  
[www.invacare.be](http://www.invacare.be)  
[belgium@invacare.com](mailto:belgium@invacare.com)

### Netherlands

#### INVACARE B.V.

Celsiusstraat 46  
NL-6716 BZ Ede  
Phone: +31 318 695 757  
Fax: +31 318 695 758  
[www.invacare.nl](http://www.invacare.nl)  
[care@invacare.com](mailto:care@invacare.com)

### Germany

#### INVACARE AQUATEC GmbH

Alemannenstrasse 10  
D-88316 Isny  
Phone: +49 75 62 7 00 0  
Fax: +49 75 62 7 00 66  
[www.aquatec.de](http://www.aquatec.de)  
[info@invacare-aquatec.de](mailto:info@invacare-aquatec.de)

### Portugal

#### INVACARE Lda

Rua Senhora de Campanhã 105  
P-4369-001 Porto  
Phone: +351 225 1059 46/47  
Fax: +351 225 1057 39  
[www.invacare.pt](http://www.invacare.pt)  
[portugal@invacare.com](mailto:portugal@invacare.com)

### Australia

#### INVACARE Australia Pty Ltd

1 Lenton Place, North Rocks  
NSW 2151  
Phone: +61 2 8839 5333  
Fax: +61 2 8839 5353  
[www.invacare.com.au](http://www.invacare.com.au)  
[sales@invacare.com.au](mailto:sales@invacare.com.au)



QUALITY SYSTEM  
DS/EN ISO 9001  
DS/EN ISO 13485

### France

#### INVACARE Poirier S.A.S

Route de St. Roch  
F-37230 Fondettes  
Phone: +33 2 47 62 64 66  
Fax: +33 2 47 42 12 24  
[www.invacare.fr](http://www.invacare.fr)  
[contactfr@invacare.com](mailto:contactfr@invacare.com)

### Italy

#### INVACARE MECC SAN S.R.L.

Via dei Pini 62  
I-36016 Thiene (VI)  
Phone: +39 0445 38 00 59  
Fax: +39 0445 38 00 34  
[www.invacare.it](http://www.invacare.it)  
[italia@invacare.com](mailto:italia@invacare.com)

### United Kingdom & Ireland

#### INVACARE LTD

South Road  
Bridgend Industrial Estate  
UK-Bridgend, CF31 3PY  
Phone: +44 1 656 664 321  
Fax: +44 1 656 667 532  
[www.invacare.co.uk](http://www.invacare.co.uk)  
[uk@invacare.com](mailto:uk@invacare.com)

### New Zealand

#### INVACARE NZ

4 Westfield Place,  
Mt. Wellington  
Auckland  
Phone: +64 9 917 3939  
Fax: +64 9 917 3957  
[www.invacare.co.nz](http://www.invacare.co.nz)  
[sales@invacare.co.nz](mailto:sales@invacare.co.nz)

### Austria

#### MOBITEC MOBILITÄTSHILFEN GmbH

Herzog Odilostrasse 101  
A-5310 Mondsee  
Phone: +43 6232 5535 0  
Fax: +43 6232 5535 4  
[www.mobitec-austria.com](http://www.mobitec-austria.com)  
[austria@invacare.com](mailto:austria@invacare.com)

Manufacturer:

**INVACARE EC-Høng A/S**

Østergade 3  
DK-4270 Høng  
[www.invacarebeds.dk](http://www.invacarebeds.dk)